

THERIC PROCESSING MACHINE CO.,LTD

THERIC PROCESSING MACHINE CO.,LTD

Bulk Material Handling Machine , Equipment & Process



Big Bag Filling Station

Weighting System

Big Bag Unloading Station

Bulk Material Feeding System

Bag Dump Station

Dust Controlling System

Tote Bin Dumping Station

Automatic Control System

Pneumatic Conveying System

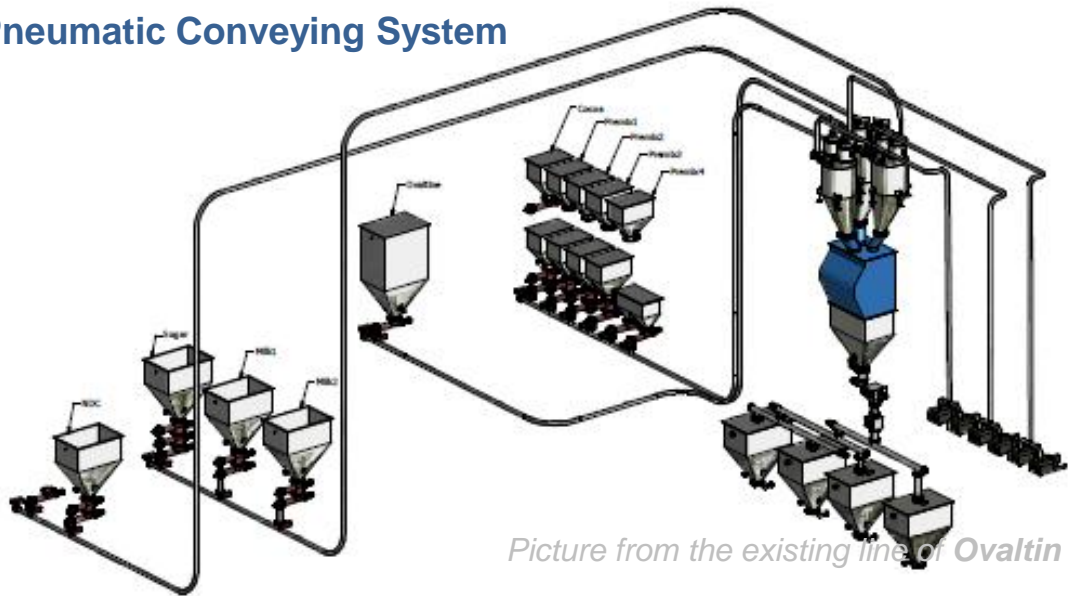

Picture from the existing line of Ovaltin

Dry Bulk Food Material Processing System



Rotary & Diverter Valve



Stainless Steel Hopper & Silo

Lump Breaker / Lump Crusher

Stainless Steel Cyclone & Receiver

Food Grade Screw Conveyor

Stainless Fabrication Work

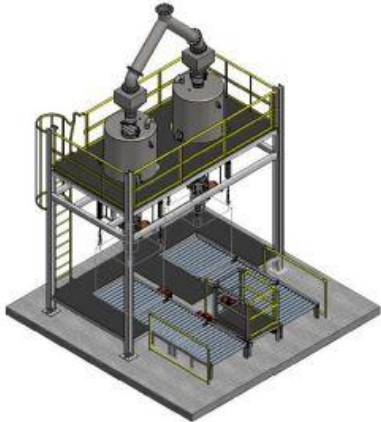

Big Bag Filling BBF-LW-XX

อุปกรณ์บรรจุวัสดุดิบไปยังถุง Big bag ที่มีประสิทธิภาพและความแม่นยำสูง สามารถบรรจุด้วยอัตราความเร็ว 20 bag/hr. 40 bag/hr. และ 60 bag/hr. @1000 kg/bag เหมาะสำหรับการบรรจุที่ต้องการ Capacity สูง ความแม่นยำสูง มีความสะอาดและความปลอดภัยในการปฏิบัติงานสูง

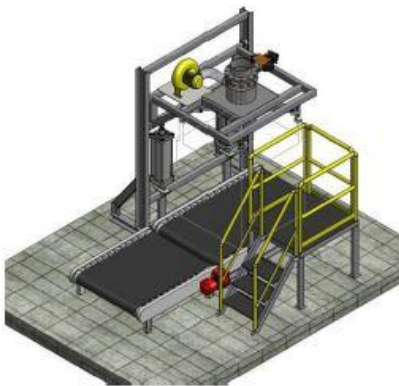

Big Bag Filling BBF-BW-A20

Big bag filling ชนิดชั่งน้ำหนักและบรรจุในเวลาเดียวกัน ควบคุมการจ่ายโดย Butterfly Valve Auto ออกแบบเพื่อความสะอาดและความปลอดภัยในการปฏิบัติงาน สามารถบรรจุด้วยอัตราความเร็วสูงสุด 20 bag/hr. @1000 kg/bag เหมาะสำหรับการบรรจุที่ต้องการ Capacity ปานกลาง ความแม่นยำในการบรรจุปานกลาง แต่ให้มีความสะอาดและความปลอดภัยสูง

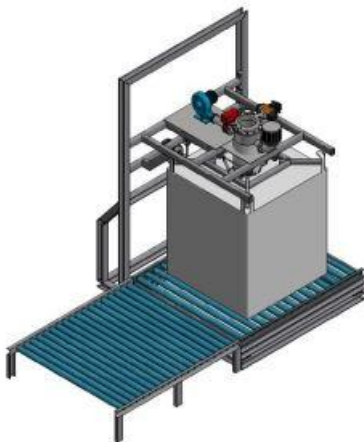

Big Bag Filling BBF-BW-B20

Big Bag Filling ที่ออกแบบเพื่อตอบสนองเรื่องต้นทุนมาพร้อมอุปกรณ์ทำงานมาตรฐาน Option การยก Big bag ขึ้น-ลงเพื่อปรับให้ใช้งานได้กับ Big bag หลายขนาด พร้อมระบบ Weighting Scale และอื่นๆ Big bag filling รุ่นนี้เหมาะสำหรับการบรรจุที่ต้องการ Capacity ปานกลาง ความแม่นยำปานกลาง ความสะอาดและความปลอดภัยในการปฏิบัติงานปานกลาง แต่ด้วยราคาที่ต่ำกว่าจึงตอบสนองเรื่องต้นทุนได้ดี

Big Bag Unloader

สะดวก และประหยัดเวลาในการปฏิบัติงาน ด้วย Big bag Unloader ที่มีประสิทธิภาพ พร้อมด้วยฟังก์ชันการทำงานให้สะดวกปลอดภัย

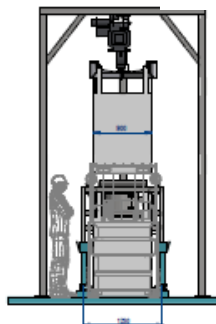
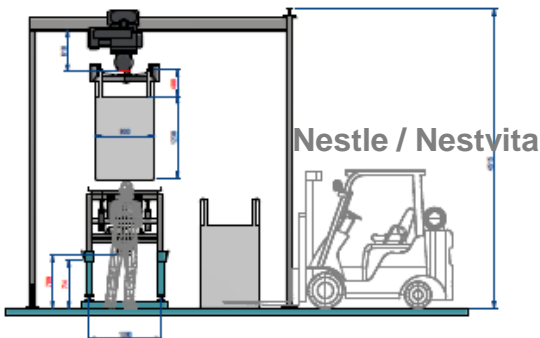
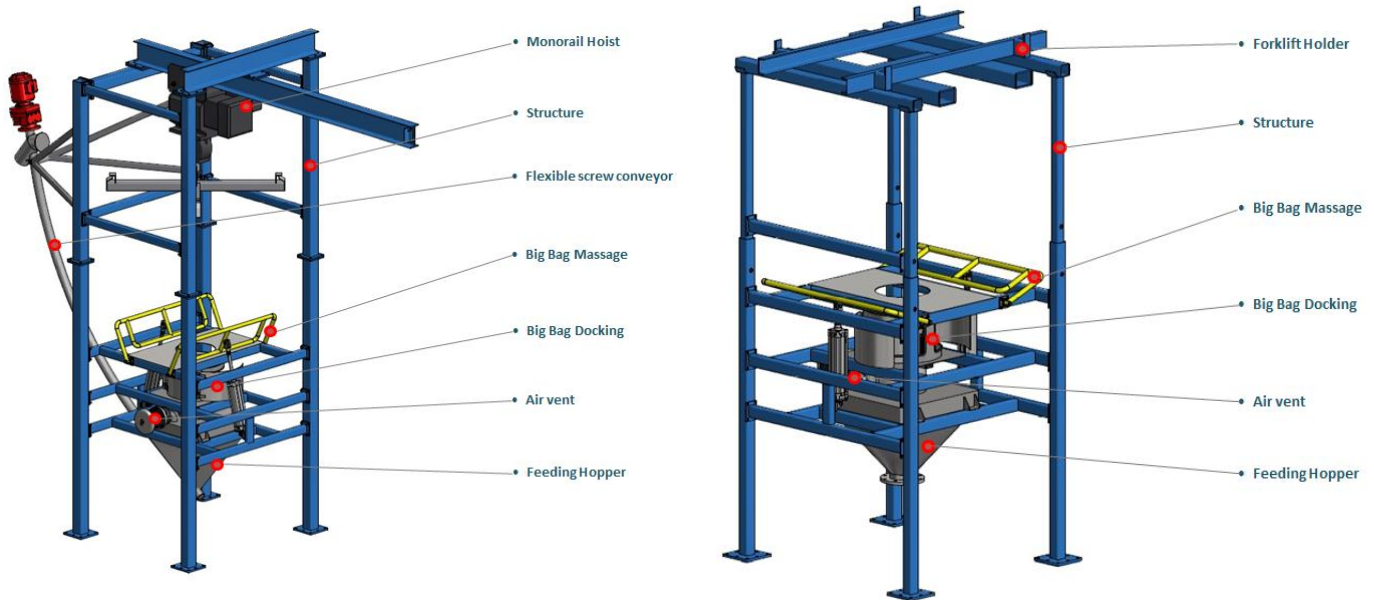

Tailor made Big Bag Unloading Station to be suited with the special requirement

AB Food / Ovaltin

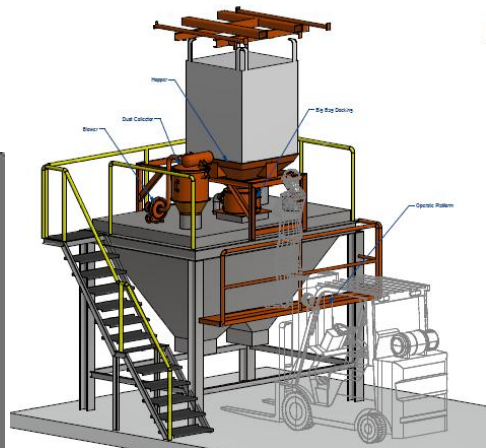
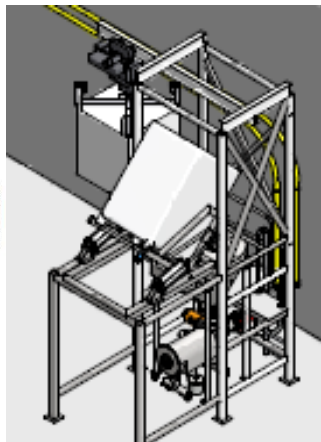
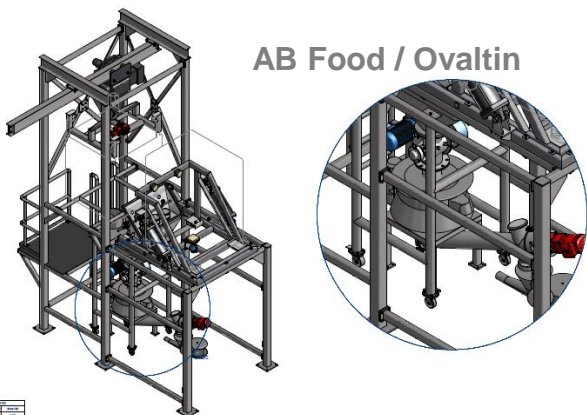

Big Bag & Tote Bin Dumping Station



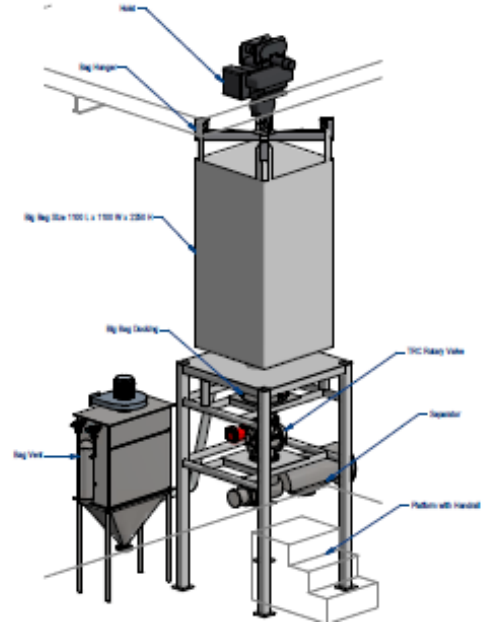
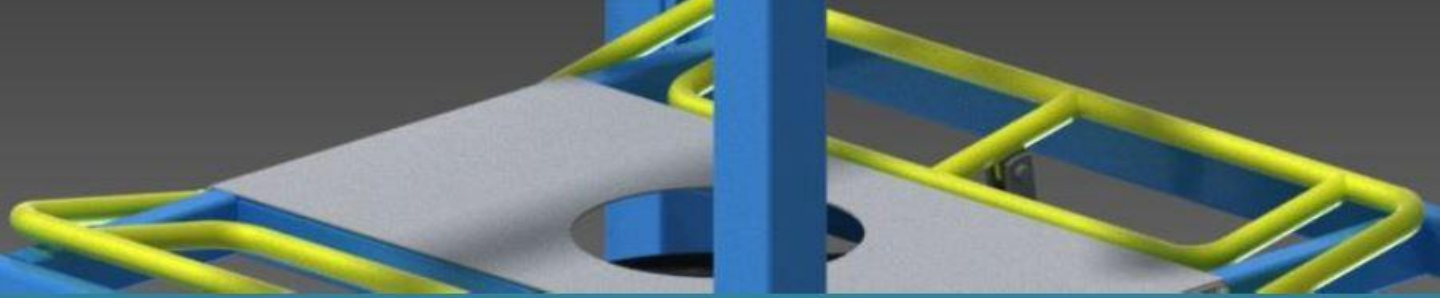

Small Bag Dump Station & Bulk Bag unloading Station with Dust Free Solution

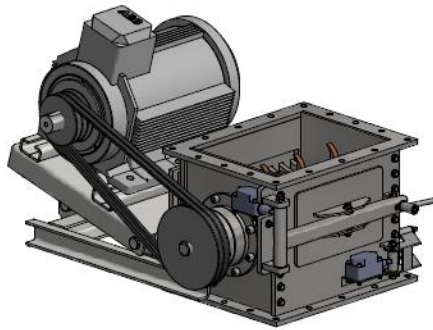
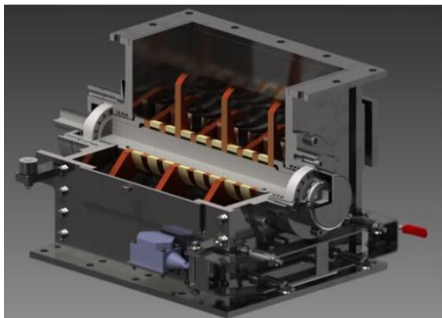

Lump Breaker (Lump Crusher)

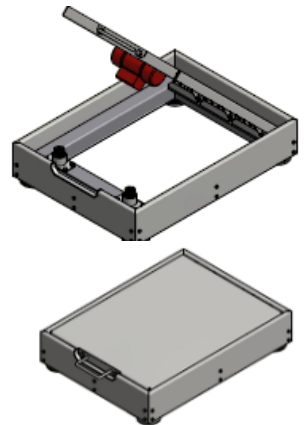

Easy clean stainless steel rotary valve

Compacting table for Small bag filling

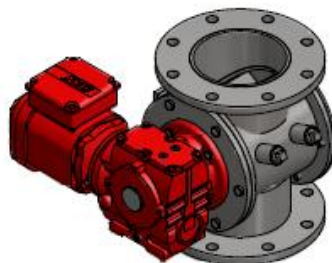

Moving Head for Tote bin filling





Bulk Material Conveying system (Dust prove, Close system)

Food Grade Screw Conveyor, inside parts polished, Easy detachable for quick cleaning

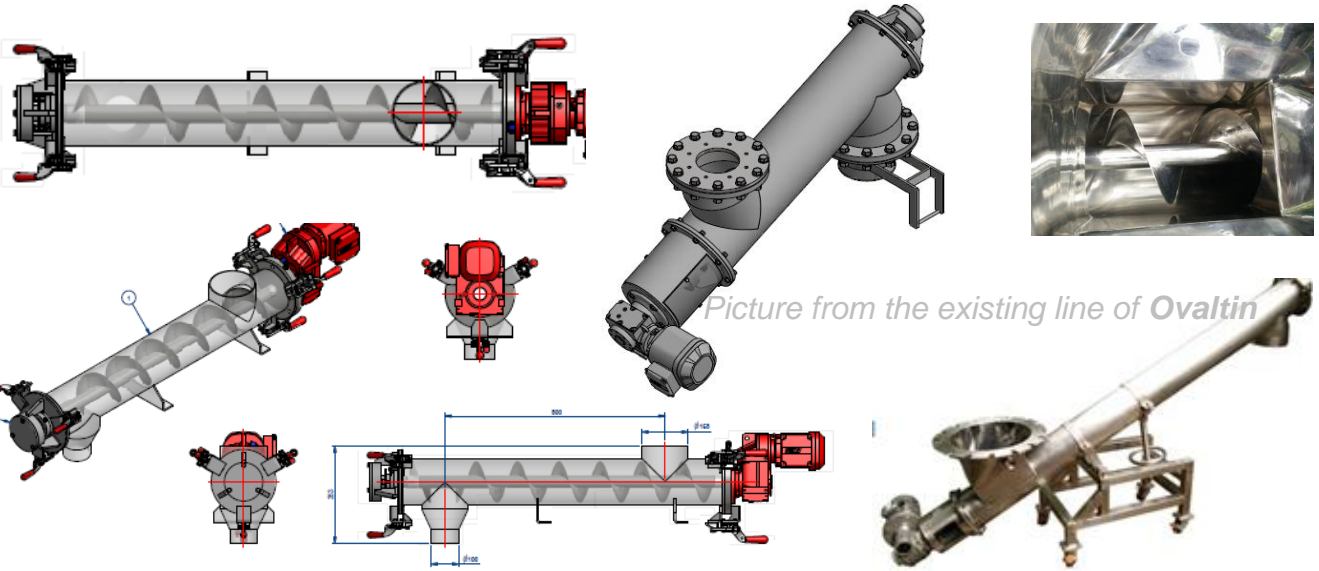

Pneumatic conveying system for versatile loading system

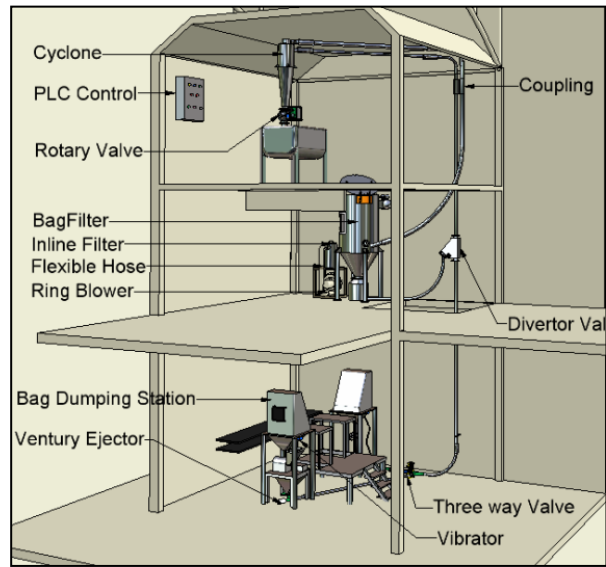
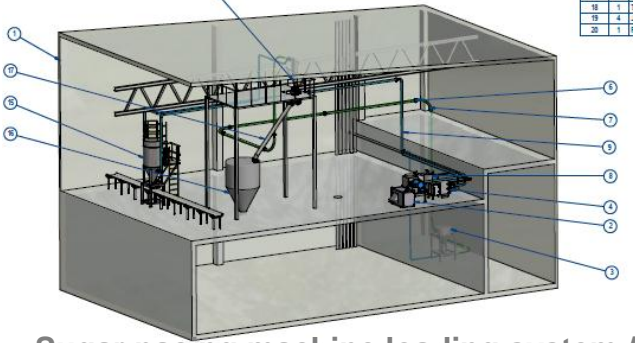
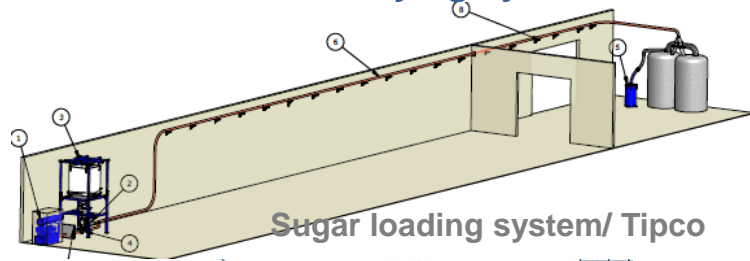

3 in 1 coffee system / Cefona

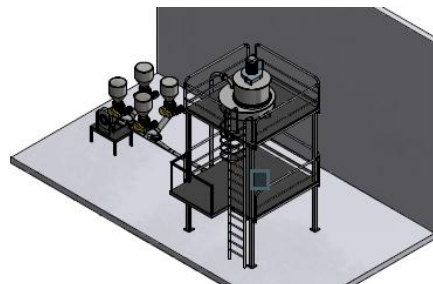
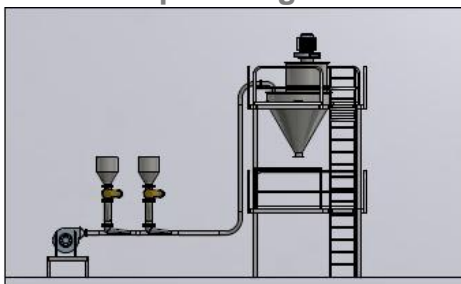

Ovaltin loading system/ AB Food



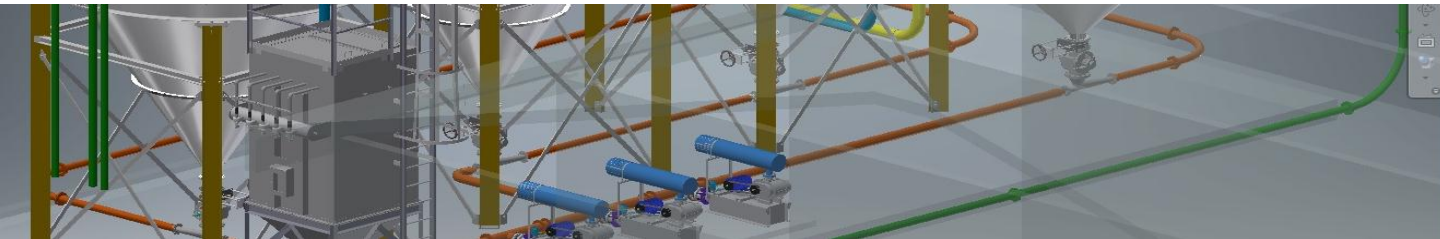

THEREC PROCESSING MACHINE CO.,LTD

Storage Silos & Accessories

Aluminium Knock Down Silo / Made in Netherlands

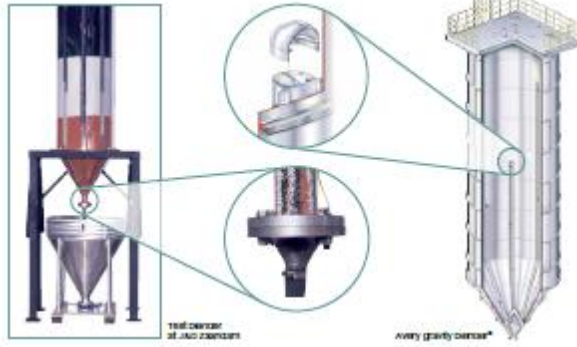

Gravity Blender



Polyester Fabric Flexible silos



Silo Loading Bellow



Industrial Load cell / Made in UK



Tension operating
Self centering
Pendulum design



Low profile mounting
assembly
Atex & IECEx Certification



Silo mount



Smart Digital Display



Junction box



Anti vibration assembly



Install and Removal without lifting tool



www.trpm.co.th

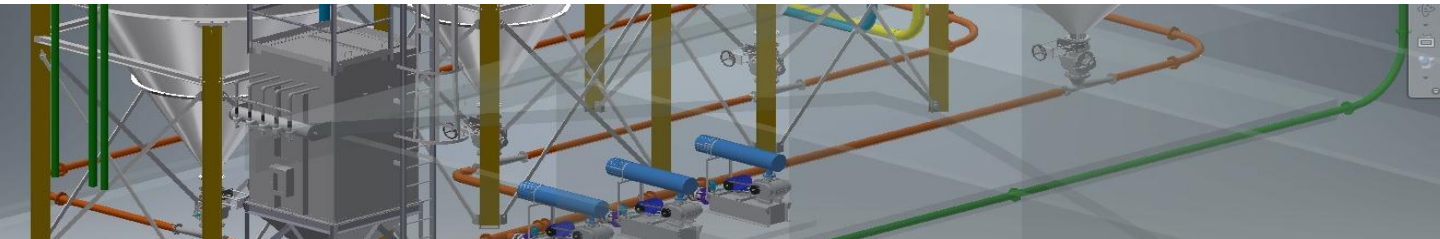

THEREC PROCESSING MACHINE CO.,LTD

Bulk Material Handling Machine



Flexible Spiral Conveyor



Capacity : 120-10.000 kg/hr / Tube size 40-130 mm. / Bulk Density up to 700 kg/m³



Continuous Mixer



Volumetric ,Gravimetric and Vibration Feeder



Aero Mechanical Conveyor

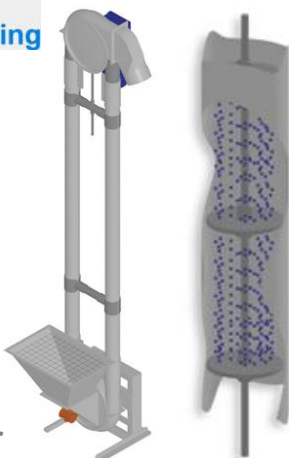

Centrifugal Sifter



FlowSWITCH 500M
Flow switch for
bulk material
handling
process monitoring



Mass flow meter



MF300
Compact and
economical inline
measurement



www.trpm.co.th

PVC pipe (PVC resin, PVC scrap and CaCa₃) processing system

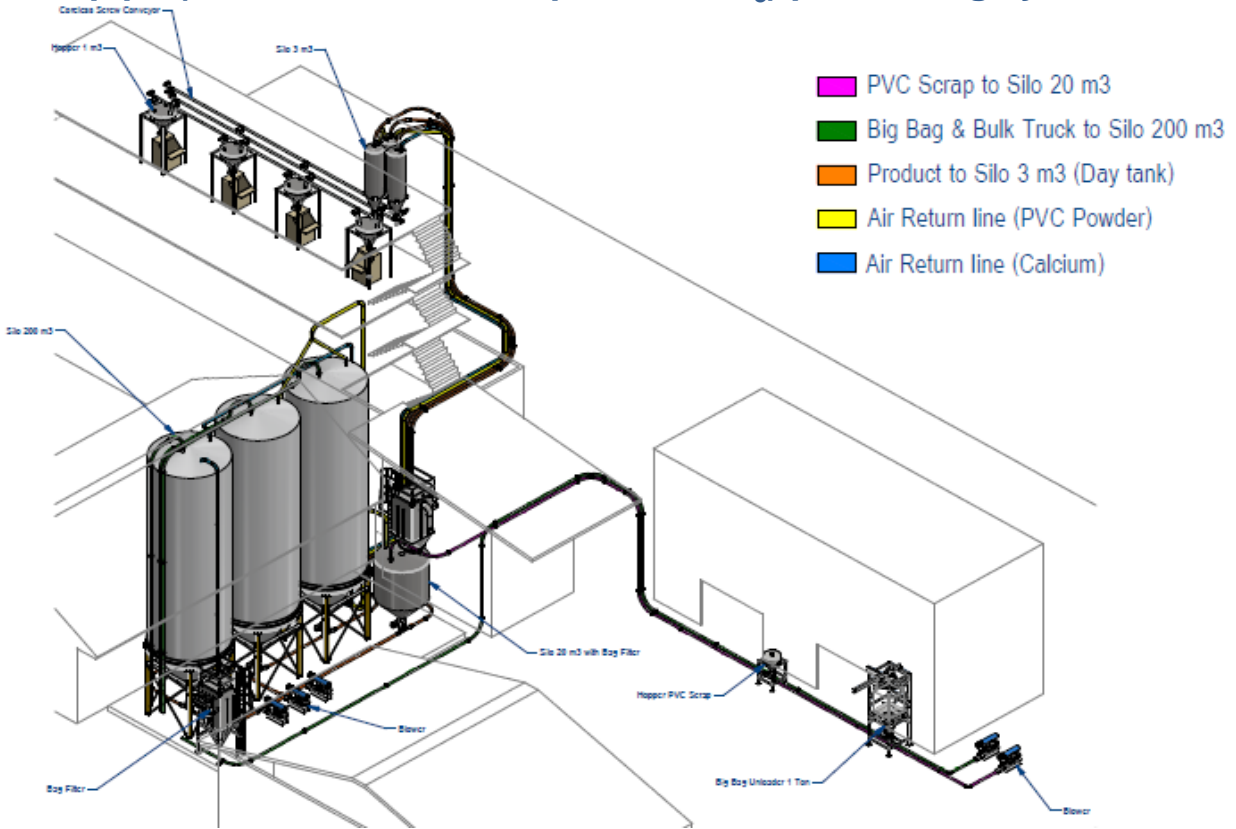

The total system consisting of :

- 3 of 200.0 m³ Aluminum knock down silos
- 1 of 20.0 m³ Stainless steel silos
- 3 of 3.0 m³ Carbon steel day tanks
- 3 of 17.5 meter long Spiral coreless screw feed, with 1 inlet & 5 outlet ports
- 4 of 1.0 m³ Carbon steel weighting hoppers
- 1 of 300 kg Weighting system for 3 types of raw material to 4 ribbon mixers with 10 formulas of raw material mixing , automatic memories operation with adjustable page ,allow only the authorized person with pass word add and renew
- 5 of 5.0 tons Pneumatic conveying systems
- 1 of Big bag unloading station
- 5 of High pressure ring blowers 30 kw
- 7 of Heavy duty air lock rotary valves , Carbon steel body with hard chromed
- 2 of Bag filters for dust controlling system, with 3,000 m³ centrifugal fan
- 2 of Electrical control box, with SEMENS S7 1200 PLC with PROFACE touch screen , suitable for full automatic operation and SCADA system requirement

บริษัทเทอร์เรคโพรเซสซิงแมชชีนจำกัด

THEREC

THEREC PROCESSING MACHINE CO.,LTD.

TherEC Processing Machine Co., Ltd. www.trpm.co.th.com

Tel (662) 893 9003-4 (5 lines)

Fax : (662) 893 9005 ,893 9178

88 Soi Karnjanapisek 4/2 Karnjanapisek Rd. Bangbon Bangkok
10150 Thailand

General product TRPM 01 / 2014