

THEREC CORPORATION LTD.

Industrial Gas Handling system package

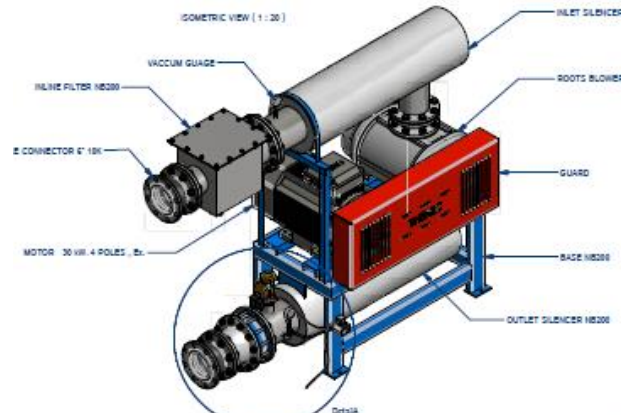
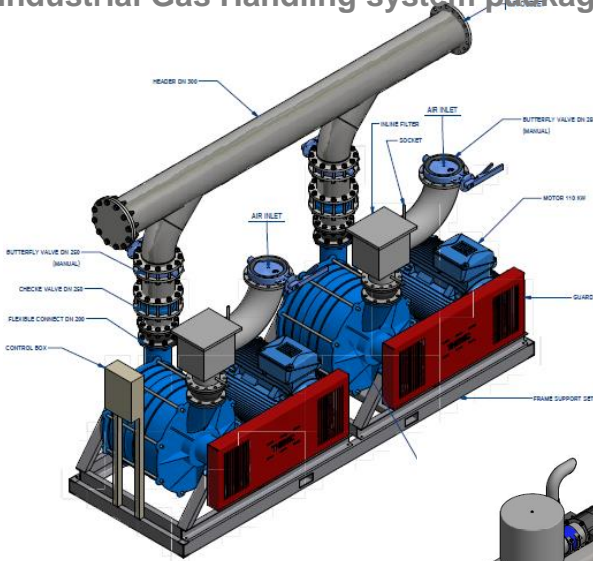

Biogas Handling system package

Installation, Service & Commissioning

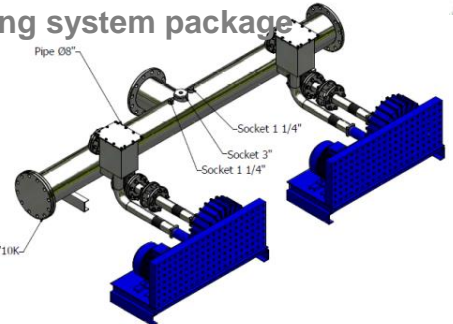
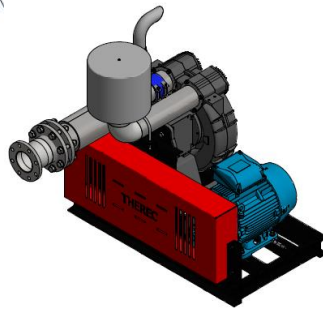

Package System Engineering

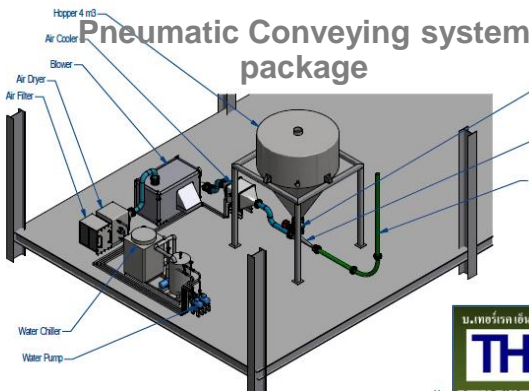

Pneumatic Conveying system package

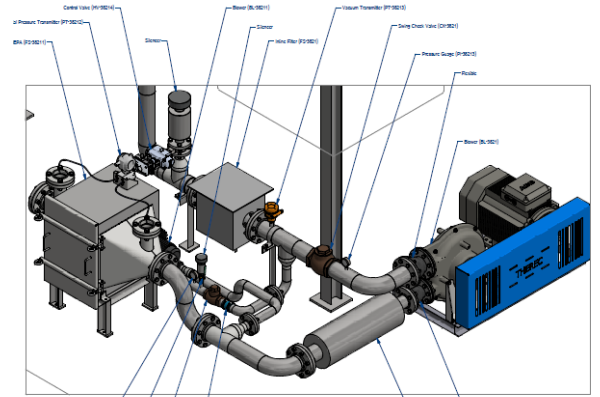

Central Vacuum cleaning system package

Factory, R&D and Test Center

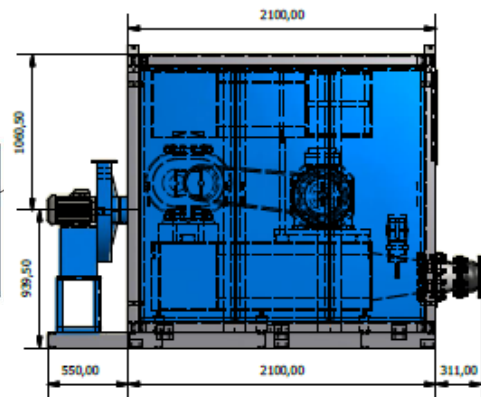
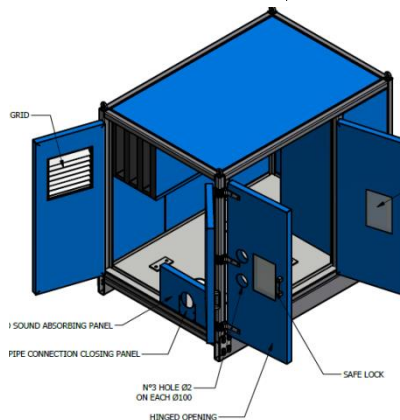
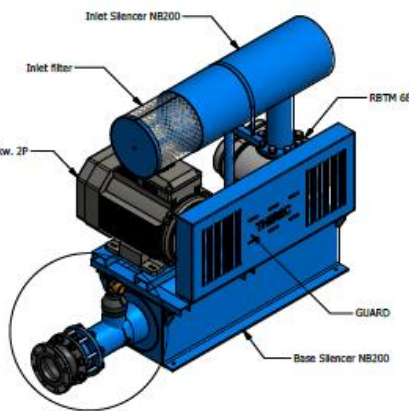

Standard Roots blower package for Waste water treatment

Industrial Blower Engineering Package



Rotary / Roots Blower Package



Acoustic Enclosure Air Blower Package



Hot Dip Galvanized Coating Package

Standard Gas Blower Package

Multi Stage Centrifugal Blower Package



Side channel (Ring) Blower Package

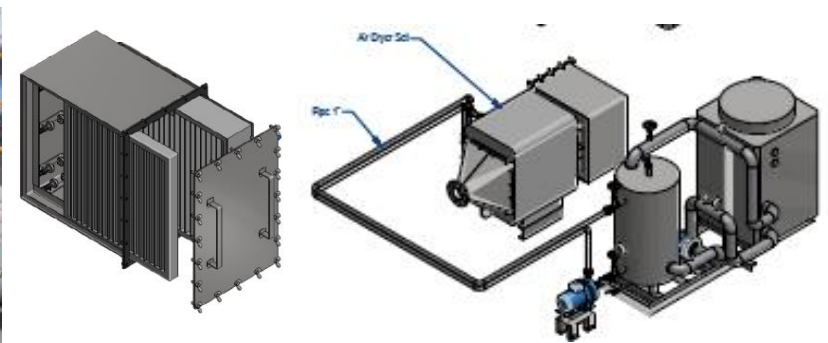

Air filter , Air Cooler or Air dryer and Control system with total Installation & Commissioning Service

Engineering system design support Service for both Air and Gas Handling process /Loss ,Pressure, Flow and Etc.

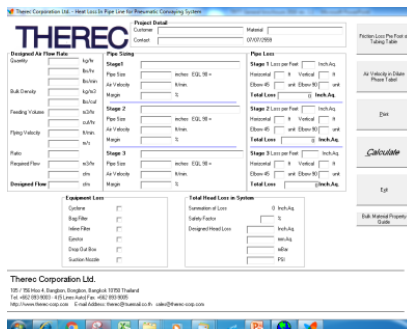
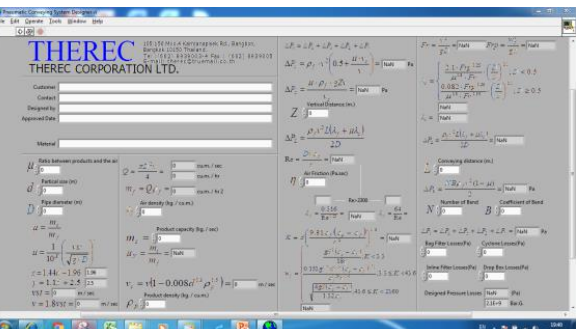

The sizing program both from our principle oversea and in house development by THEREC

Roots blower Air & Gas Boosting Engineering package

Industrial process Roots blower control package unit

DRESSER Roots offer fully engineered packaged blower units designed to meet customer requirements. Pre-assembled skid-mounted packages, with all piping, valves and instrumentation in place are produced for pressure or vacuum applications allowing for simple on-site installation.

▼ A two-stage DVJ dry vacuum pump package for non-cryogenic air separation by VSA (Vacuum Swing Adsorption).

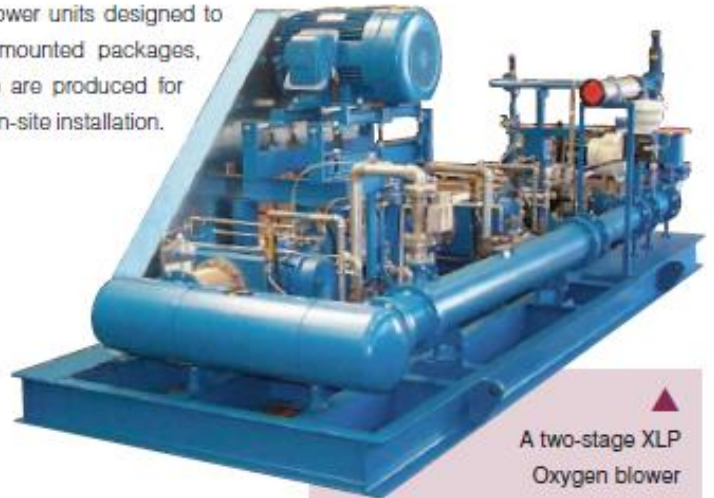

▲ A two-stage XLP Oxygen blower package.



▲ RAM 406-G-DPJ high pressure gas blower for digester gas applications.

▼ This two-stage VJ vacuum pump package is employed on VSA (Vacuum Swing Adsorption) duty.



Howden
ROOTS™

Therec Air & Gas Boosting & Handling system ref.

Temperature & Moisture control system

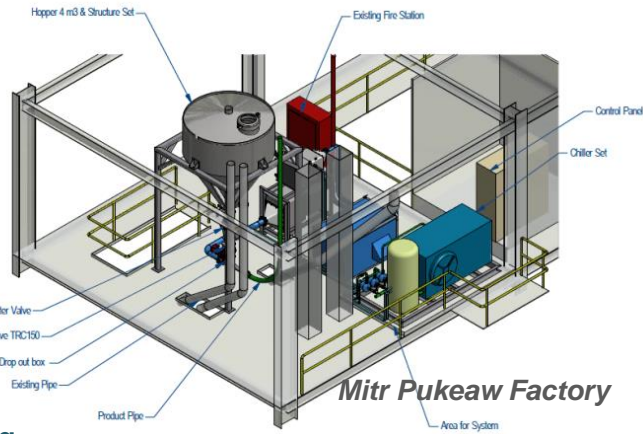
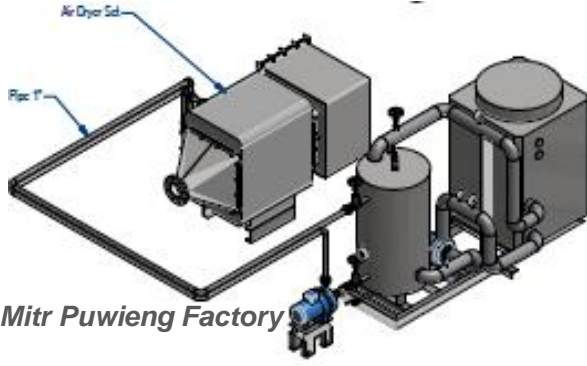

Mitr Puwieng Factory

Mitr Pukeaw Factory

Mitrphol Sugar Co., Ltd./ Sugar pneumatic conveying

Contacted conveying air moisture control to the level below 35% relative humidity to protect the sugar lump and stickiness from ambient moisture.

Contacted temperature to be under 38 degree C, to protect the internal moisture from flashing out and make the crystal to be dim.

SCADA control system with SIEMENS S7 300 series PLC

Vacuum control system

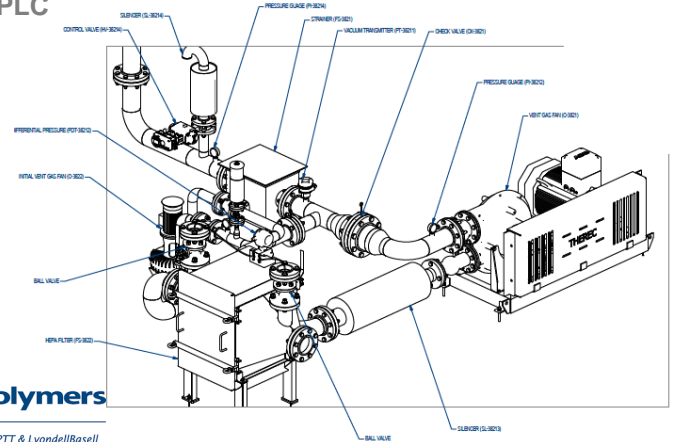
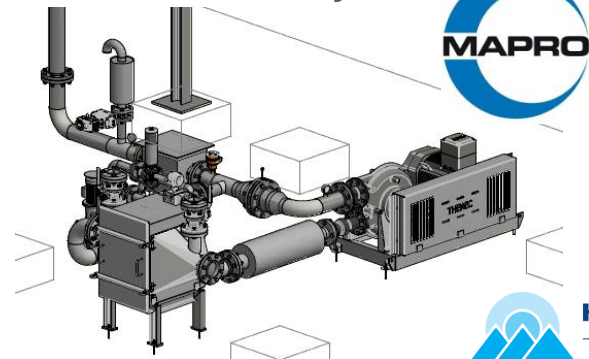

HMC Polymer Co., Ltd./ PTT Group of company, job in cooperation with CR Asia

Vacuum control system for central vacuum cleaning system operation, operated by vacuum transmitter and pneumatic control valve to maintain the vacuum level of the system at -300 mBar and maintain the averaged suction air volume of each individual suction point at around 200 cfm of all working condition. Also the differential pressure switch for the filters.

SCADA control system with ALAN BRADLEY 500 series PLC

Pressure control system

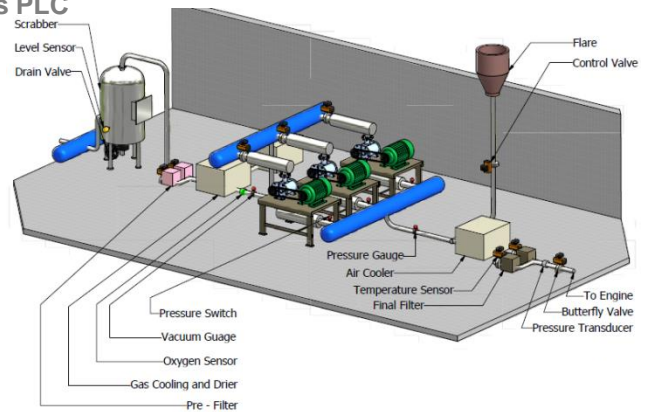
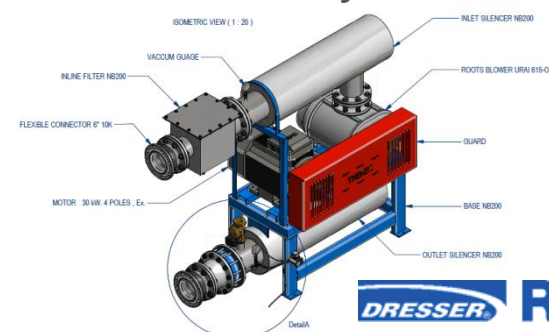

Chareon Sompong Co., Ltd./ Underground Biogas from landfill site

Pressure control system for bio gas boosting station / supply to gas engine of electrical generator By pressure transmitter and pneumatic control valve to maintain the pressure of 7 PSI supply to engine regulator and over supply gas to the flare with gas cooler and cooling tower set to maintain the feed in gas to be under 50 degree C and reduced the water content level in the biogas.

Also with oxygen sensor/transmitter and safety vacuum switch.

SCADA control system with SIEMENS S7 200 series PLC

TRC / Therec's Machine & Component Company

Rotary and Diverter Valve maker / Lump breaker manufacturer
Bulk material handling Valve, Component & Machine importer
Blowers and Vacuum pump importer
High pressure blower engineering package designer & packer
Bulk Bag Filling & Weighting machine manufacturer
Small bag tipping station & Big bag unloading station maker

TRT / Therec's Silo & Tank Making Company

Food grade stainless steel work shop.
Stainless steel Hopper Tank and Silos
Special design bag filter & cyclone

TRE&C / Therec's Powder & Bulk material processing Company

Pneumatic conveying system / Sea bulk loading system
Powder and Bulk material Weighting & Metering system
Powder & Dust explosion protection system
Central vacuum dust cleaning system
Air & Gas boosting & handling system

Clear & **C**omplete engineering process design with the main components of the process coming from a single group, precisely matched for the influences system operation with the full reliable service team.

“Over all knowledge summation of the 20 years experience”

Therec Corporation Co, Ltd.

Tel (662) 893 9003-4 (5 lines)

Fax : (662) 893 9005 ,893 9178

88 Soi Karnjanapisek 4/2 Karnjanapisek Rd. Bangbon Bangkok 10150 Thailand

www.therecorp.com / System Therec 01 / 2017